

1/4 to 1/11 DUTY FIP(VFD) CONTROLLER/DRIVER

DESCRIPTION

The SC16312 is a FIP (Fluorescent Indicator Panel, or Vacuum Fluorescent Display) controller/driver that is driven on a 1/4 or 1/11 duty factor. It consists of 11 segment output lines, 6 grid output lines, 5 segment/grid output drive lines, a display memory, a control circuit, and a key scan circuit. Serial data is input to the SC16312 through a three-line serial interface. This FIP controller/driver is ideal as a peripheral device for a single-chip microcomputer.

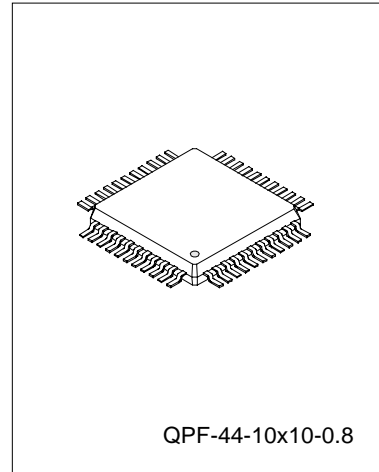

FEATURES

- * Multiple display modes (11-segment & 11-dight to 16-segment & 4-digit).
- * Key scanning (6x4 matrix).
- * Dimming circuit (eight steps).
- * High-voltage output ($V_{DD} - 35V$ max).
- * LED ports (4 chs., 20 mA max).
- * General-purpose input port (4 bits)
- * No external resistors necessary for driver outputs (P-ch open-drain + pull-down resistor output)
- * Serial interface (CLK, STB, DIN, DOUT)

PAD CONFIGURATION

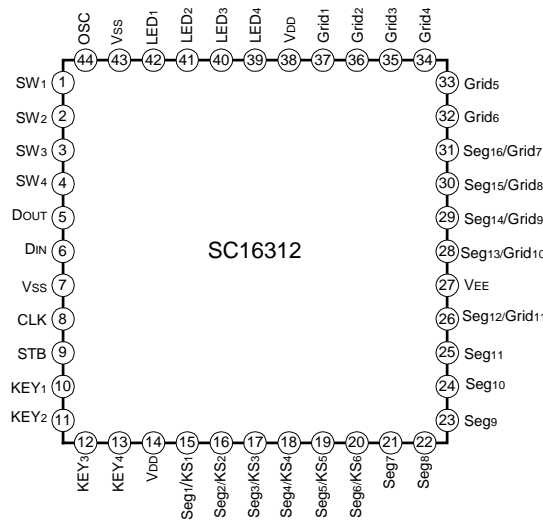

BLOCK DIAGRAM

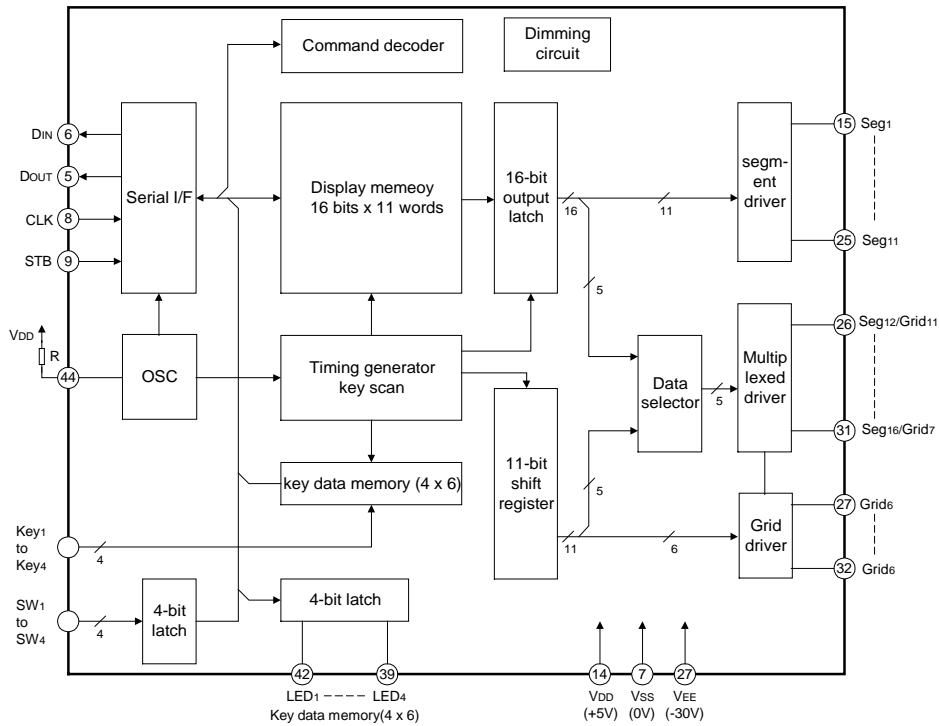

ABSOLUTE MAXIMUM RATING (Ta=25°C, Vss=0V)

Characteristic	Symbol	Value	Unit
Logic Supply Voltage	VDD	-0.5 ~ 7.0	V
Driver Supply Voltage	VEE	VDD + 0.5 ~ VDD - 40	V
Logic Input Voltage	V _{I1}	-0.5 ~ VDD + 0.5	V
FIP Driver Output Voltage	VO ₂	VEE - 0.5 ~ VDD + 0.5	V
LED Driver Output Current	IO ₁	+25	mA
FIP Driver Output Current	IO ₂	-40 (grid) ; -15 (segment)	mA
Power Dissipation	PD	800 *	mW
Storage temperature	T _{STG}	-65 ~ +150	°C
Operating Ambient Temperature	T _{OPT}	-40 ~ + 85	°C

* Note: Derate at -6.4 mW/°C at Ta=25°C or higher

— HANGZHOU SILAN MICROELECTRONICS JOINT-STOCK CO.,LTD —

Rev: 1.0 2000.12.31

RECOMMENDED OPERATING RANGE (Ta=-20 ~ 70 °C, Vss=0V)

Parameter	Symbol	Min	Typ	Max	Unit
Logic Supply Voltage	V _{DD}	4.5	5	5.5	V
High-Level Input Voltage	V _{IH}	0.7x V _{DD}	--	V _{DD}	V
Low-Level Input Voltage	V _{IL}	0	--	0.3xV _{DD}	V
Driver Supply Voltage	V _{EE}	0	--	V _{DD} -35	V

Maximum power consumption P_{MAX} = FIP driver dissipation + R_L dissipation + LED driver dissipation + dynamic power consumption

Where segment current = 3mA, grid current = 15mA, and LED current = 20mA,

FIP driver dissipation = number of segments x 6 + number of grids/(number of grids + 1) x 30(mW)

R_L dissipation = (V_{DD}-V_{EE})² /50 x (number of segments + 1)(mW)

LED driver dissipation = number of LEDs x 20(mW)

Dynamic power consumption = V_{DD} x 5(mW)

Example

Where V_{EE} = -25V, V_{DD} = 5V, and in 16-segment and 6-digit modes,

FIP driver dissipation = 16 x 6 +6/7 x 30 = 122

R_L dissipation = 30² /50 x 17 = 306

LED driver dissipation = 4 x 20 = 80

Dynamic power consumption = 5 x 5 = 25

Total 553 Mw

ELECTRICAL CHARACTERISTICS (Ta=-20 ~ 70 °C, V_{DD} =4.5 ~ 5.5V, V_{EE}=-30V)

Parameter	Symbol	Test conditions	Min	Typ	Max	Unit
High-Level Output Voltage	V _{OH1}	LED1- LED4, I _{OH1} =-1mA	0.9V _{DD}	--	--	V
Low -Level Output Voltage	V _{OL1}	LED1- LED4, I _{OL1} =20mA	--	--	1	V
Low -Level Output Voltage	V _{OL2}	D _{OUT} , I _{OL2} =4mA	--	--	0.4	V
High-Level Output Current	I _{OH21}	V _O =V _{DD} -2V, Seg ₁ to Seg ₁₁	-3	--	--	mA
High-Level Output Current	I _{OH22}	V _O =V _{DD} -2V, Grid ₁ to Grid ₆ Seg ₁₂ /Grid ₁₁ to Seg ₁₆ /Grid ₇	-15	--	--	mA
Driver Leakage Current	I _{OLEAK}	V _O = V _{DD} -35V,driver off	--	--	-10	μA
Output Pull-Down Resistor	R _L	Driver output	50	100	150	kΩ
Input Current	I _I	V _I =V _{DD} or V _{SS}	--	--	±1	μA
High-Level Input Voltage	V _{IH}	--	0.7V _{DD}	--	--	V
Low-Level Input Voltage	V _{IL}	--	--	--	0.3V _{DD}	V
Hysteresis voltage	V _H	CLK, D _{IN} , STB	--	0.35	--	V
Dynamic Current Consumption	I _{DDdyn}	Under no load, display off	--	--	5	mA

— HANGZHOU SILAN MICROELECTRONICS JOINT-STOCK CO.,LTD —

Rev: 1.0 2000.12.31

SWITCHING CHARACTERISTICS ($T_a = -20 \sim 70 \text{ }^\circ\text{C}$, $V_{DD} = 4.5 \sim 5.5\text{V}$, $V_{EE} = -30\text{V}$)

Parameter	Symbol	Test conditions	Min	Typ	Max	Unit
Oscillation Frequency	t_{OSC}	$R=51\Omega$	350	500	650	kHz
Propagation Delay Time	t_{PLZ}	CLK \rightarrow DOUT	--	--	300	ns
	t_{PZL}	$C_L=15\text{pF}$, $R_L=10\text{k}\Omega$	--	--	100	ns
Rise Time	t_{TZH1}	$C_L=300\text{pF}$ Seg ₁ to Seg ₁₁ Grid ₁ to Grid ₆ , Seg ₁₂ /Grid ₁₁ to Seg ₁₆ /Grid ₇	--	--	2	μs
	t_{TZH2}		--	--	0.5	μs
Fall Time	t_{THZ}	$C_L=300\text{pF}$, Seg _n , Grid _n	--	--	120	μs
Maximum Clock Frequency	f_{max}	Duty=50%	1	--	--	MHz
Input Capacitance	C_i	--	--	--	15	pF

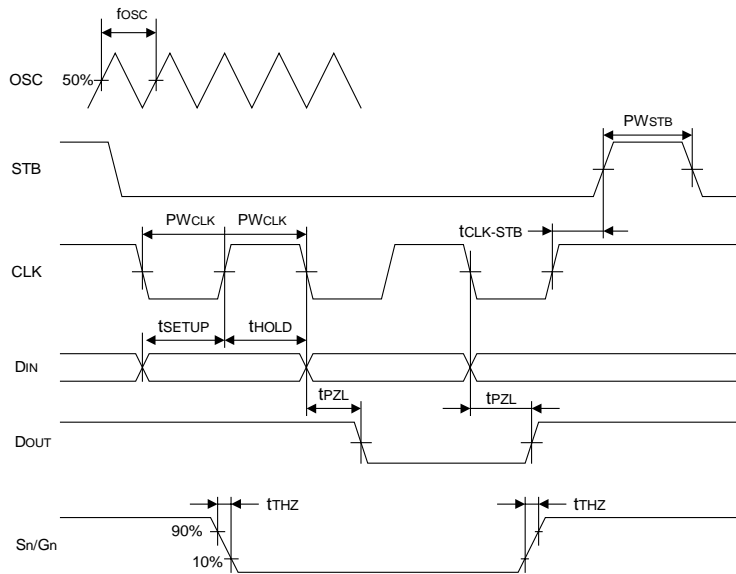
SWITCHING CHARACTERISTIC WAVEFORMS

TIMING CONDITIONS($T_a = -20 \sim 70 \text{ }^\circ\text{C}$, $V_{DD} = 4.5 \sim 5.5\text{V}$)

Parameter	Symbol	Test conditions	Min	Typ	Max	Unit
Clock Pulse Width	PW _{CLK}	--	400	--	--	ns
Strobe Pulse Width	PW _{STB}	--	1	--	--	μs
Data Setup Time	t _{SETUP}	--	100	--	--	ns
Data Hold Time	t _{HOLD}	--	100	--	--	ns
Clock-Strobe Time	t _{CLK-STB}	CLK \uparrow \rightarrow STB \uparrow	1	--	--	μs
Wait Time	t _{WAIT}	CLK \uparrow \rightarrow CLK \downarrow ^{Note}	1	--	--	μs

Note: When data is read, a wait time t_{WAIT} of 1 μs is necessary since the rising of the eighth clock that has set the command, until the falling of the first clock that has read the data.

PAD DESCRIPTION

Pin No.	Symbol	Pin Name	Description
6	D _{IN}	Data input	Input serial data at rising edge of shift clock, starting from the low order bit.
5	D _{OUT}	Data output	Output serial data at the falling edge of the shift clock, starting from low order bit. This is N-ch open-drain output pin.
9	STB	Strobe	Initializes serial interface at the rising or falling edge of the SC16312. It then waits for reception of a command. Data input after STB has fallen is processed as a command. While command data is processed, current processing is stopped, and the serial interface is initialized. While STB is high, CLK is ignored.
8	CLK	Clock input	Reads serial data at the rising edge, and outputs data at the falling edge.
44	OSC	Oscillator pin	Connect resistor to this pin to determine the oscillation frequency to this pin.
15 ~ 20	Seg ₁ /KS ₁ to Seg ₆ /KS ₆	High-voltage output	Segment output pins (Dual function as key source).
21 ~ 25	Seg ₇ to Seg ₁₁	High-voltage output (segment)	Segment output pins.
37 ~ 32	Grid ₁ to Grid ₆	High-voltage output (grid)	Grid output pins.

(to be continued)

(continued)

Pin No.	Symbol	Pin Name	Description
26,28 ~ 31	Seg ₁₂ /Grid ₁₁ to Seg ₁₆ /Grid ₇	High-voltage output (segment/grid)	These pins are selectable for segment or grid driving.
42 ~ 39	LED ₁ to LED ₄	LED output	CMOS output. +20mA max.
10 ~ 13	KEY ₁ to KEY ₄	Key data input	Data input to these pins is latched at the end of the display cycle.
1 ~ 4	SW ₁ to SW ₄	Switch input	These pins constitute a 4-bit general-purpose input port.
14,38	V _{DD}	Logic power	5V±10%
7,43	V _{SS}	Logic ground	Connect this pin to system GND.
27	V _{EE}	Pull-down level	V _{DD} -35V max.

FUNCTIONAL DESCRIPTION

1. DISPLAY RAM ADDRESS AND DISPLAY MODE

The display RAM stores the data transmitted from an external device to the SC16312 through the serial interface, and is assigned addresses as follows, in 8 bits unit:

Seg ₁	Seg ₄	Seg ₈	Seg ₁₂	Seg ₁₆	
00HL	00Hu	01HL	01Hu		DIG ₁
02HL	02Hu	03HL	03Hu		DIG ₂
04HL	04Hu	05HL	05Hu		DIG ₃
06HL	06Hu	07HL	07Hu		DIG ₄
08HL	08Hu	09HL	09Hu		DIG ₅
0AHL	0AHu	0BHL	0BH _u		DIG ₆
0CHL	0CH _u	0DHL	0DH _u		DIG ₇
0EHL	0EH _u	0FHL	0FH _u		DIG ₈
10HL	10Hu	11HL	11Hu		DIG ₉
12HL	12Hu	13HL	13Hu		DIG ₁₀
14HL	14Hu	15HL	15Hu		DIG ₁₁

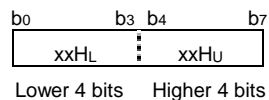

2. KEY MATRIX AND KEY-INPUT DATA STORAGE RAM

The key matrix is made up of a 6 x 4 matrix, as shown below.

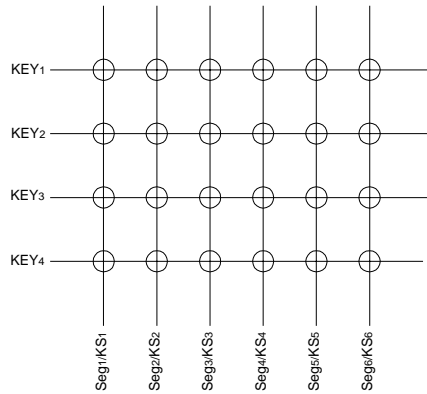

The data of each key is stored as illustrated below, and is read with the read command, starting from the least significant bit.

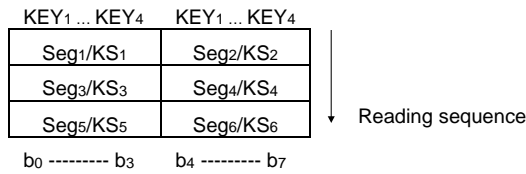

3. LED PORT

Data is written to the LED port with command, starting from the least port's least significant bit. When a bit of this port is 0, the corresponding LED lights; When the bit is 1, the LED turns off. The data of bits 5 through 8 are ignored.

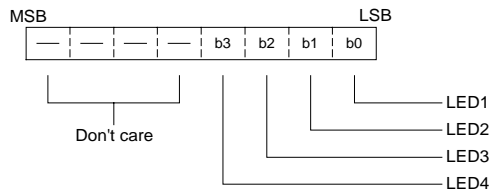

On power application, all LEDs are unlit.

4. SW DATA

SW data is read with the read command, starting from the least significant bit. Bits 5 through 8 of the SW data are 0.

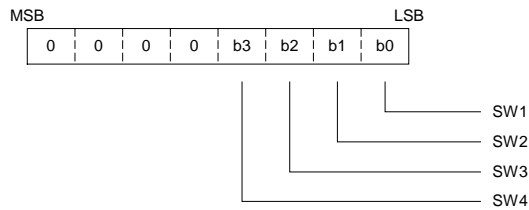

5. COMMANDS

Commands set the display mode and status of the FIP driver.

The first 1 byte input to the SC16312 through the DIN pin after the STB pin has fallen is regarded as a command.

If STB is set high while commands/data are transmitted, serial communication is initialized, and the commands/data being transmitted are invalid(however, the commands/data previously transmitted remain valid).

(1) Display mode setting commands

These commands initialize the SC16312 and select the number of segments and the number of grid(1/4 to 1/11 duty, 11 segments to 16 segments).

When these commands are executed, the display is forcibly turned off, and key scanning is also stopped. To resume display, the display command "ON" must be executed. If the same mode is selected, however, nothing happens.

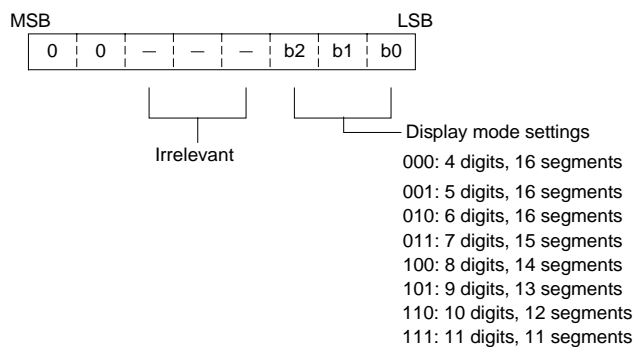

On power application, the 11-digit, 11-segment mode is selected.

(2) Data setting commands

These commands set data write and data read modes.

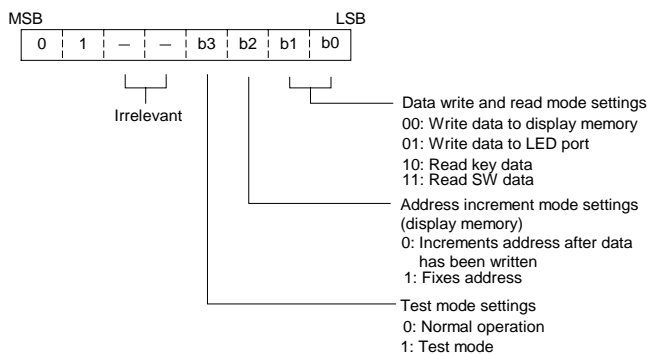

On power application, the normal operation and address increment modes are set.

(3) Address setting commands

These commands set an address of the display memory.

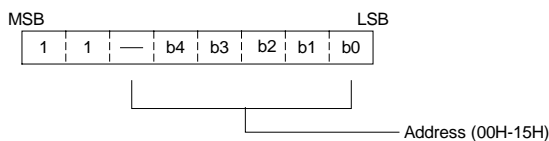

If address 16H or higher is set, data is ignored, until a valid address is set.

On the power application, the address is set to 00H.

(4) Display control commands

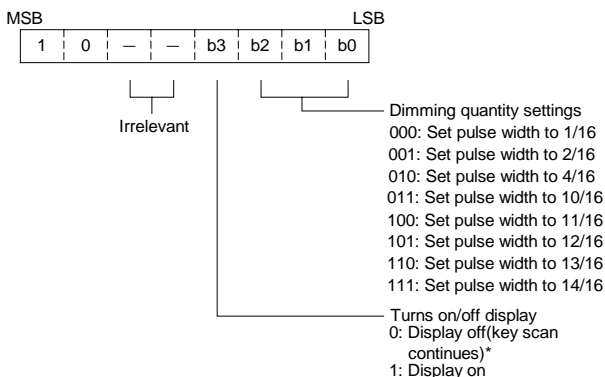

On power application, the 1/6 pulse width is set and the display is turned off.

*Note: On power application, key scanning is stopped.

KEY SCANNING AND DISPLAY TIMING

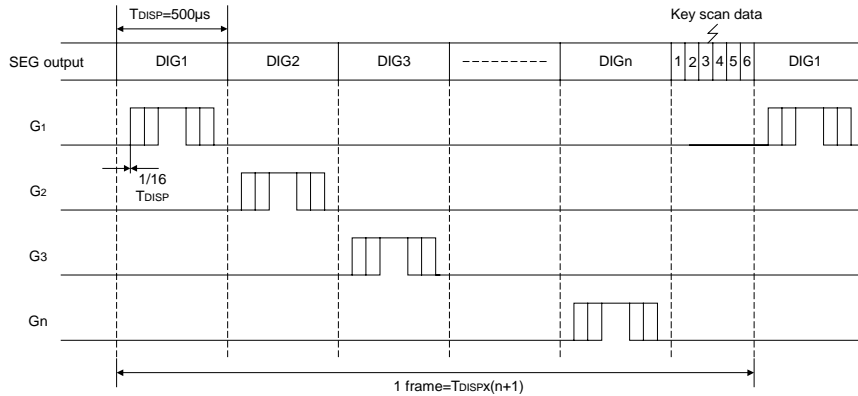

One cycle of key scanning consists of one frame, and data in a 6x4 matrix is stored in RAM.

SERIAL COMMUNICATION FORMAT

Reception(command/data write)

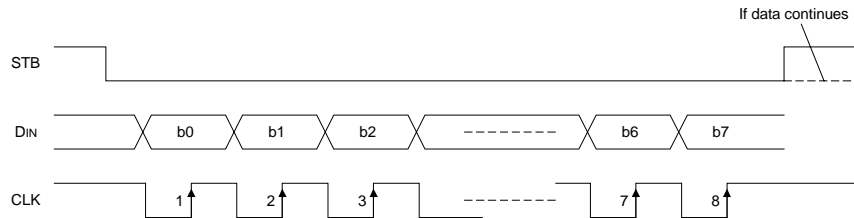

Transmission(data read)

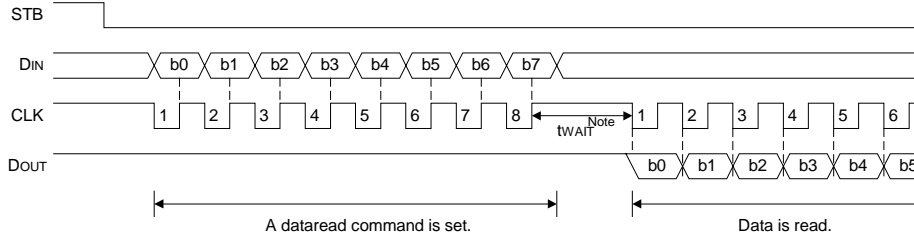

Because the DOUT pin is an N-ch, open-drain output pin, be sure to connect an external pull-up resistor to this pin(1kΩ to 10kΩ)..

APPLICATION

Updating display memory by incrementing address

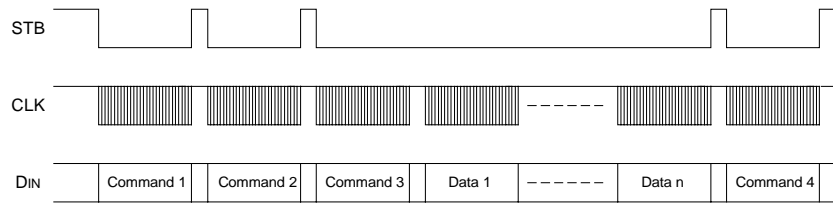

- Command1: sets display mode
- Command2: sets data
- Command3: sets address
- Data 1 to n: transfers display data(22 bytes max.)
- Command4: controls display

Updating specific address

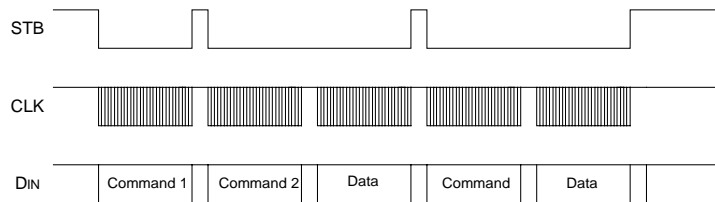

- Command1: set data
- Command2: sets address
- Data: display data

PACKAGE OUTLINE

